

REVISION HISTORY			
REV	DESCRIPTION	DATE	APPROVED
0	ECO-01412	6/1/2004	WSS
1	ECO-02683	10/12/2009	FED

1

Bill of Material						
ITEM	PART NUMBER	STOCK NUMBER	QTY	DESCRIPTION	FILE NAME	REV
1	BPEBX100		1	ENHANCED BRUSH GROMMET BOTTOM PANEL ASSEMBLY	I001151.iam	2
2	BPES29BX100		1	REAR COVER PLATE - 29"W ENHANCED	I000159.ipt	2
3	H01-078	H01-078	6	SCREW, 10-32x1/2" PH PAN TYPE 23 BLACK OXIDE/WAX RoHS	SCR1032X500BLK.ipt	-

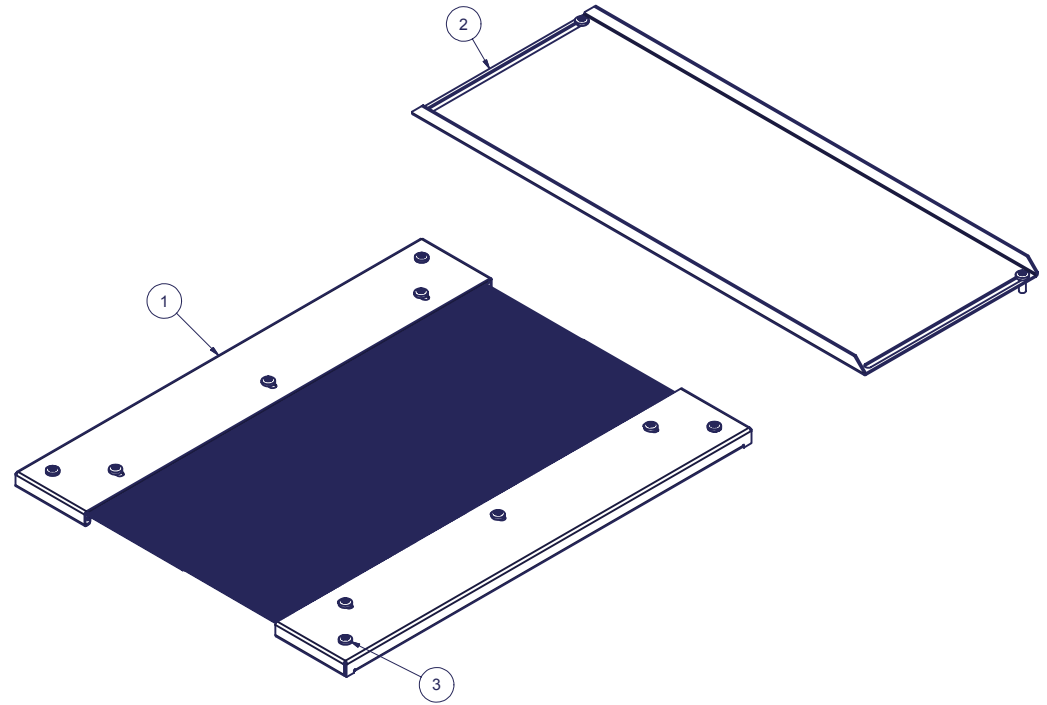
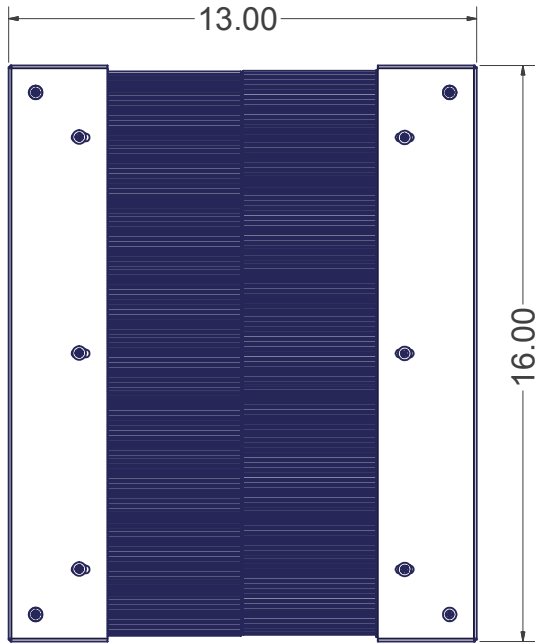
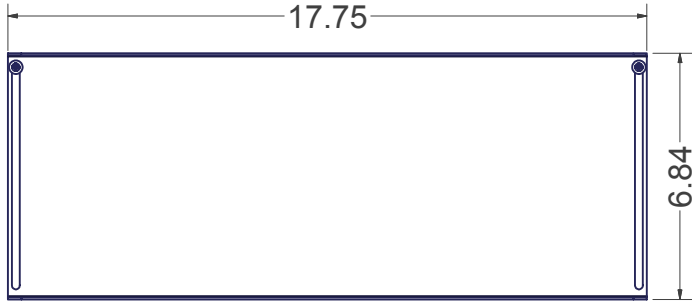

INTERPRET DRAWING PER ASME Y14.5M-1994  
 DIMENSIONAL LIMITS APPLY  
 AFTER APPLICATION OF FINISH  
 DRAWING NOT TO SCALE  
 TOLERANCE UNLESS OTHERWISE NOTED:  
 ANGULAR +/- 1°  
 .XXXX +/- .010  
 .XXX +/- .015  
 .XX +/- .030  
 .X FOR REF. ONLY  
 UNLESS OTHERWISE SPECIFIED  
 ALL DIMENSIONS ARE IN INCHES

**NOTICE:**  
 Use of this document is subject to a confidentiality and nondisclosure agreement with Great Lakes Case & Cabinet Co., Inc. (GLCC) and may not be reproduced, disclosed or utilized in whole or in part without prior written authorization from GLCC.

PART NUMBER:  
**BPB29**  
 QTY PER UNIT: 1  
 MATERIAL TYPE:  
 CRS  
 MATERIAL GAUGE:  
**#16 GA**  
 FINISH:  
 -  
 DRAWN: WSS DATE: 5/28/2004  
 CHECKED & APP. J.A.L. DATE: 6/1/04

TITLE  
**ENHANCED BRUSH GROMMET BOTTOM KIT - 29" WIDE FRAME.**  
**GREAT LAKES CASE & CABINET CO., INC.**  
 P.O. BOX 551 EDINBORO, PA 16412  
 PHONE (814) 734-7303 FAX (814) 734-3907  
 E-MAIL glcc@greatcabinets.com  
 DWG NO: **I002227**  
 REV: **1**  
 SHEET: 1 OF 2



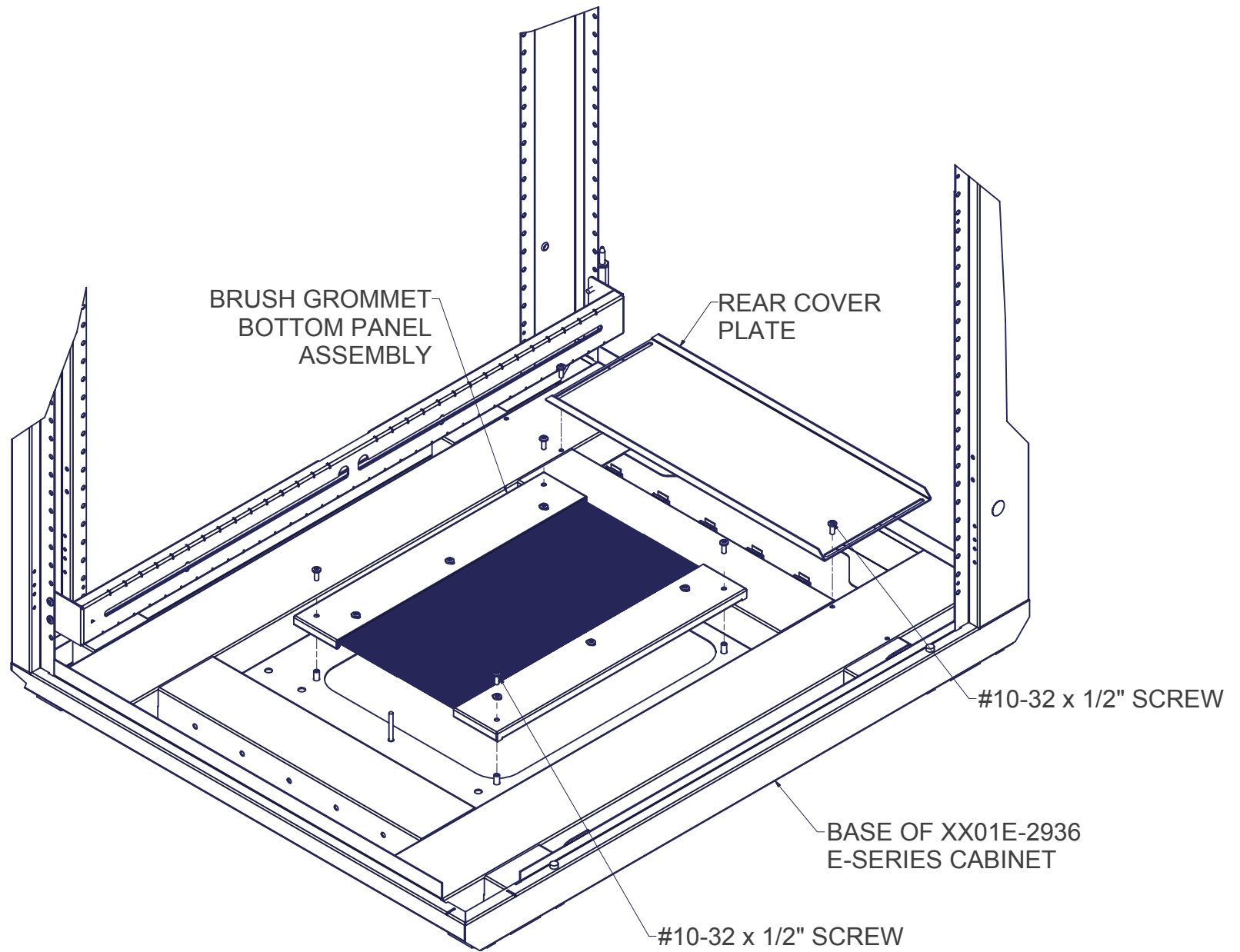

BRUSH GROMMET  
BOTTOM PANEL  
ASSEMBLY

REAR COVER  
PLATE

#10-32 x 1/2" SCREW

BASE OF XX01E-2936  
E-SERIES CABINET

#10-32 x 1/2" SCREW



THIRD ANGLE  
PROJECTION

INTERPRET DRAWING PER ASME Y14.5M-1994  
DIMENSIONAL LIMITS APPLY  
AFTER APPLICATION OF FINISH  
DRAWING NOT TO SCALE  
TOLERANCE UNLESS OTHERWISE NOTED:  
ANGULAR +/- 1°  
.XXXX +/- .010  
.XXX +/- .015  
.XX +/- .030  
.X FOR REF. ONLY

UNLESS OTHERWISE SPECIFIED  
ALL DIMENSIONS ARE IN INCHES

**NOTICE:**

Use of this document is subject to a confidentiality and nondisclosure agreement with Great Lakes Case & Cabinet Co., Inc. (GLCC) and may not be reproduced, disclosed or utilized in whole or in part without prior written authorization from GLCC.

PART NUMBER: <b>BPB29</b>	
QTY PER UNIT:	1
MATERIAL TYPE:	CRS
MATERIAL GAUGE:	
FINISH:	-
DRAWN	DATE
JL	9/8/2005
CHECKED & APP.	DATE
WSS	9-8-05

TITLE <b>ENHANCED BRUSH GROMMET BOTTOM KIT - 29" WIDE FRAME</b>	
GREAT LAKES CASE & CABINET CO., INC. P.O. BOX 551 EDINBORO, PA 16412 PHONE (814) 734-7303 FAX (814) 734-3907 E-MAIL glcc@greatcabinets.com	
DWG NO: <b>1002227</b>	REV <b>1</b>
SHEET: 2 OF 2	