

| REVISION HISTORY | | | |
|------------------|-------------|------------|----------|
| REV | DESCRIPTION | DATE | APPROVED |
| 2 | ECO-02683 | 10/12/2009 | FED |

| Bill of Material | | | | | | |
|------------------|------------------|--------------|-----|---|----------------------|----------|
| ITEM | PART NUMBER | STOCK NUMBER | QTY | DESCRIPTION | FILE NAME | REVISION |
| 1 | 10/32NUT | H02-001 | 6 | #10-32 NUT W/ EXTERNAL TOOTH LOCK WASHER | 10-32NUT.iam | - |
| 2 | | | 2 | CUSTOM BRACKET FOR BRUSH GROMMET | I001152.ipt | 1 |
| 3 | | | 2 | PRECISION BRUSH #A40, METAL CHANNEL | I001153.ipt | 0 |
| 4 | | | 2 | PRECISION BRUSH #4 BRUSH, #SK23120 | I001154.ipt | 0 |
| 5 | SCR1032X1/2BLK | H01-078 | 4 | #10-32 x 1/2"L PAN HEAD PHIL TYPE 23 , BLACK | SCR1032X500BLK.ipt | - |
| 6 | SCR1032X1/4BLK23 | H01-073 | 6 | #10-32 x 1/4"L PAN HEAD PHIL TYPE 23 SCREW, BLACK | SCR1032X250BLK23.ipt | - |
| 7 | ICBPEB | | 1 | INSTRUCTION SHEET FOR BPEBX100 - MTG. IN ENC. | I001326 | 0 |

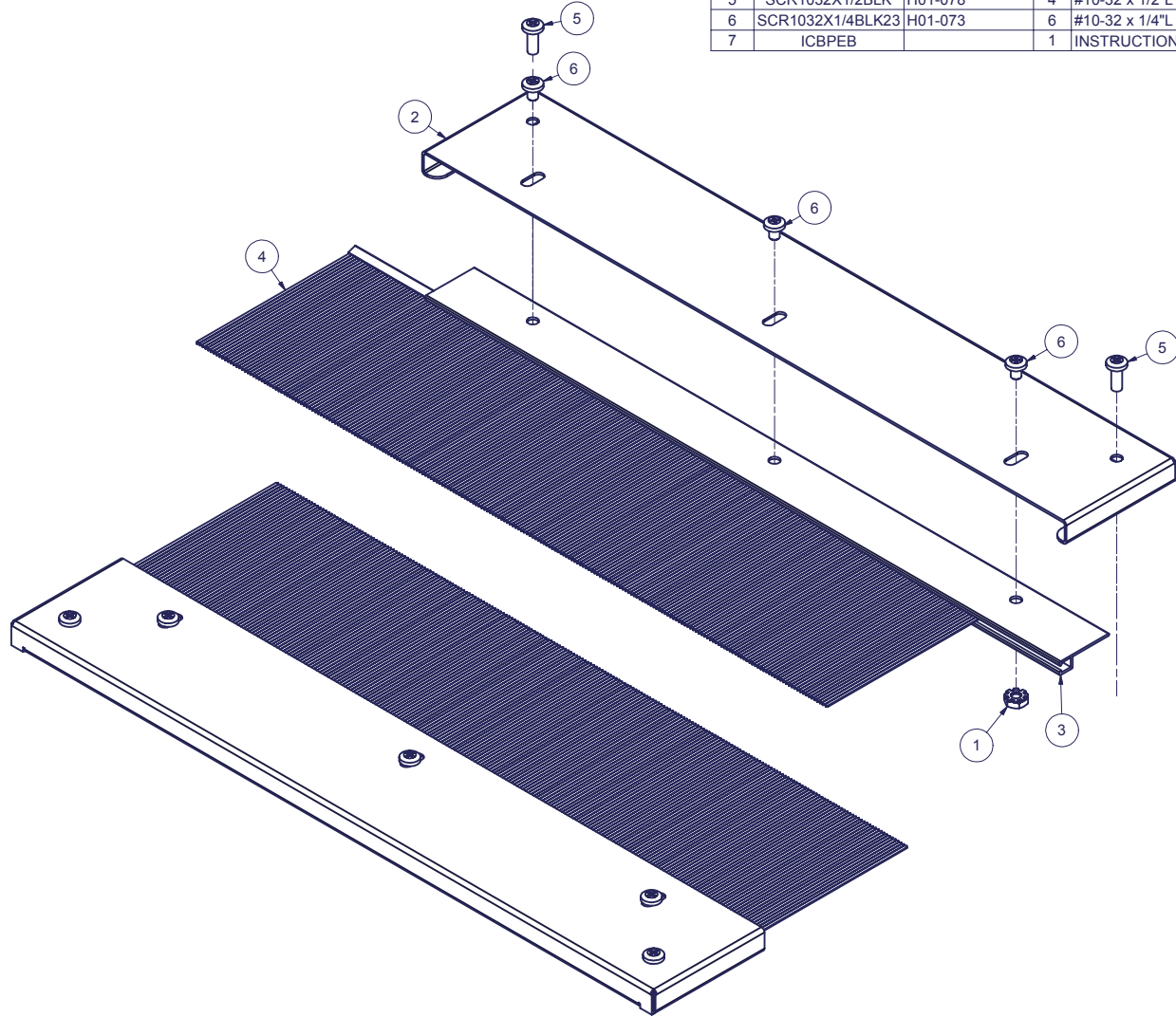

INTERPRET DRAWING PER ASME Y14.5M-1994
 DIMENSIONAL LIMITS APPLY
 AFTER APPLICATION OF FINISH
 DRAWING NOT TO SCALE
 TOLERANCE UNLESS OTHERWISE NOTED:
 ANGULAR +/- 1-
 .XXXX +/- .010
 .XXX +/- .015
 .XX +/- .030
 .X FOR REF. ONLY
 UNLESS OTHERWISE SPECIFIED
 ALL DIMENSIONS ARE IN INCHES



NOTICE:
 Use of this document is subject to a confidentiality and nondisclosure agreement with Great Lakes Case & Cabinet Co., Inc. (GLCC) and may not be reproduced, disclosed or utilized in whole or in part without prior written authorization from GLCC.

PART NUMBER:
BPEB
 QTY PER UNIT: 1
 MATERIAL TYPE:
CRS
 MATERIAL GAUGE:
#16 GA
 FINISH:
-
 DRAWN CA DATE 2/6/2003
 CHECKED & APP. AL DATE 2-6-03

TITLE
ENHANCED BRUSH GROMMET BOTTOM PANEL ASSEMBLY
GREAT LAKES CASE & CABINET CO., INC.
 P.O. BOX 551 EDINBORO, PA 16412
 PHONE (814) 734-7303 FAX (814) 734-3907
 E-MAIL glcc@greatcabinets.com
 DWG NO:
I001151
 REV
2
 SHEET: 1 OF 1

D
C
B
A

D
C
B
A

6 5 4 3 2 1