

REVISION HISTORY			
REV	DESCRIPTION	DATE	APPROVED
0	ECO-06340	10/6/2014	FED

Bill of Material					FILE NAME	Rev
ITEM	PART NUMBER	STOCK #	QTY	DESCRIPTION		
1	CM23X100		1	1 RMU x 19" EIA, CABLE MANAGER, VENDOR LEVEL	I022495.ipt	0
2	H01-078	H01-078	4	SCREW, 10-32x1/2" PH PAN TYPE 23 BLACK ZINC RoHS	H01-078.ipt	-
3	VP-143		5	1/4 TURN D-RING CABLE MANAGER, SMALL VERSION - SIEMON VP-143	VP-143.ipt	-

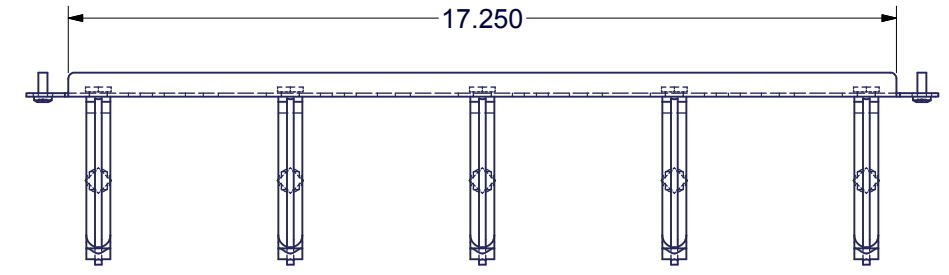

TOP VIEW

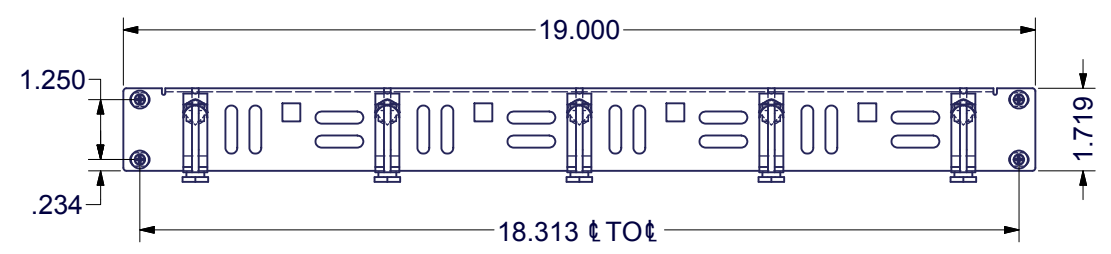

FRONT VIEW

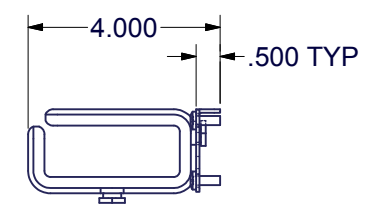

END VIEW

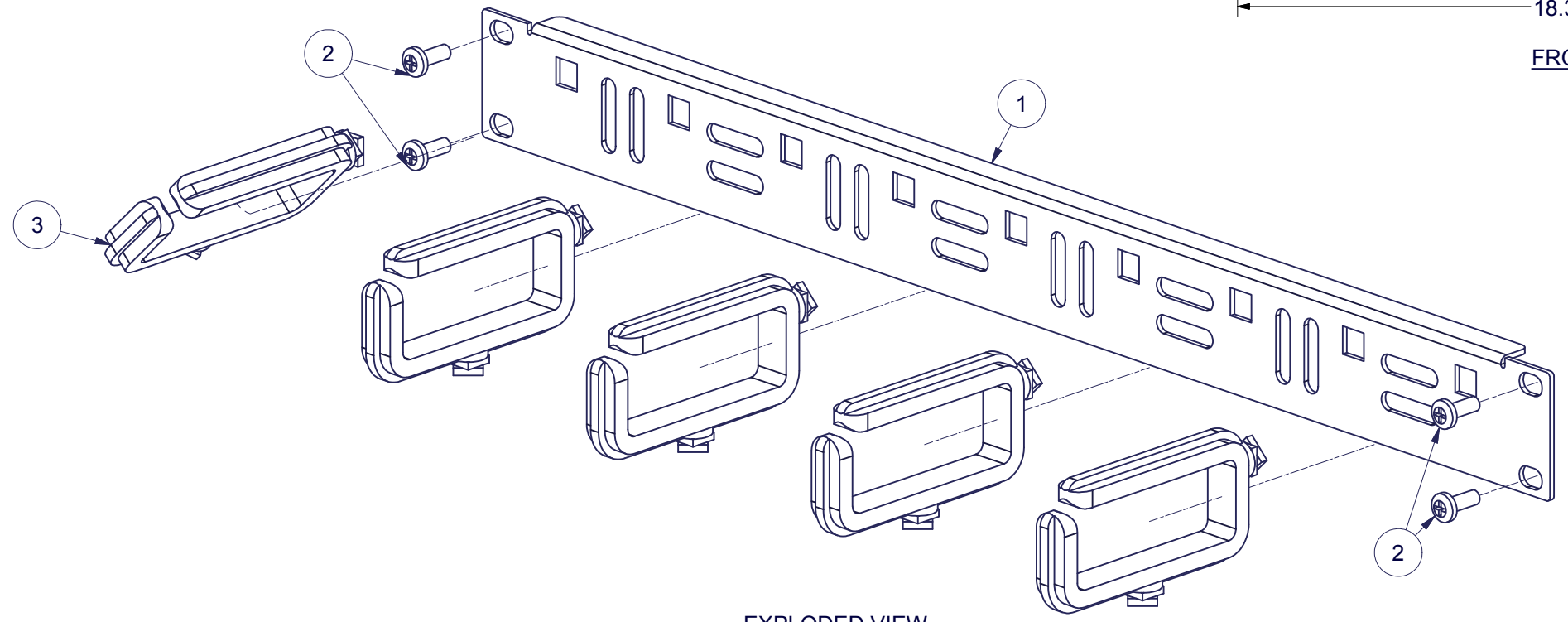

EXPLODED VIEW

**SPECIAL NOTE:**

- 1) REFER TO PURCHASE ORDER - SPECIAL REQUIREMENTS MAY APPLY!
- 2) DO NOT ASSEMBLE. SHIP AS KIT OF PARTS.

EST. WEIGHT :  
N/A



INTERPRET DRAWING PER ASME Y14.5M-1994  
DIMENSIONAL LIMITS APPLY  
AFTER APPLICATION OF FINISH  
DRAWING NOT TO SCALE  
TOLERANCE UNLESS OTHERWISE NOTED:  
ANGULAR +/- .1"  
.XXXX +/- .010  
.XXX +/- .015  
.XX +/- .030  
.X FOR REF. ONLY  
UNLESS OTHERWISE SPECIFIED  
ALL DIMENSIONS ARE IN INCHES

**NOTICE:**  
Use of this document is subject to a confidentiality and nondisclosure agreement with Great Lakes Case & Cabinet Co., Inc. (GLCC) and may not be reproduced, disclosed or utilized in whole or in part without prior written authorization from GLCC.

PART NUMBER: CM23X200  
QTY PER UNIT: 1  
MATERIAL TYPE: CRS  
MATERIAL GAUGE:  
FINISH: POWDERCOATED  
DRAWN: FED  
DATE: 10/6/2014  
CHECKED & APP: WSS  
DATE: 10/6/2014

TITLE: 1 RMU x 19"EIA, CABLE MANAGER WITH RINGS  
GREAT LAKES CASE & CABINET CO., INC.  
P.O. BOX 551 EDINBORO, PA 16412  
PHONE (814) 734-7303 FAX (814) 734-3907  
E-MAIL glcc@greatcabinets.com  
DWG NO: I022496  
REV: 0  
SHEET: 1 OF 1