

REVISION HISTORY			
REV	DESCRIPTION	DATE	APPROVED
0	ECO-06340	10/1/2014	FED

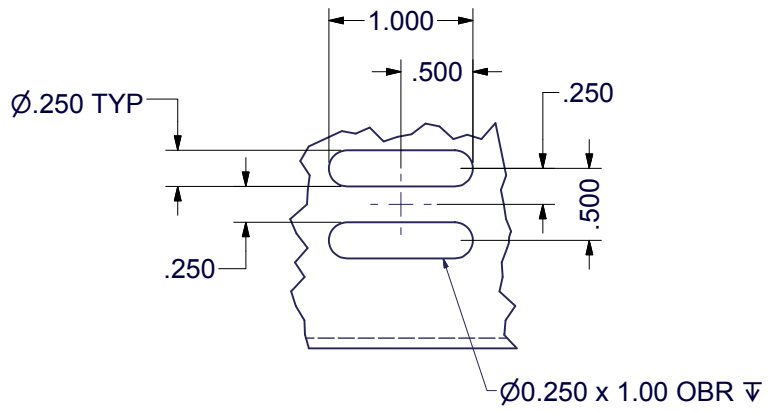

DETAIL A
TYP - (28) PLC'S

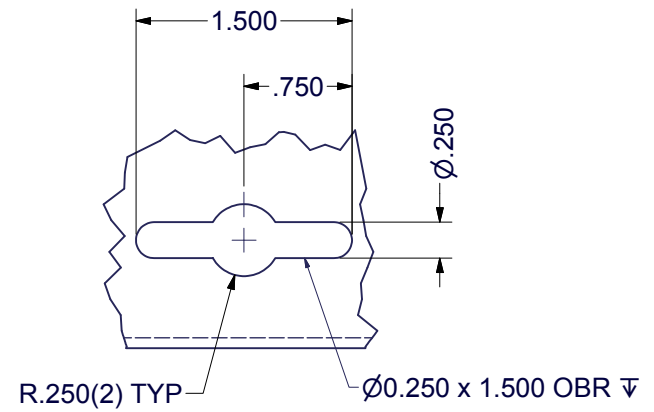

DETAIL B
TYP - (4) PLC'S

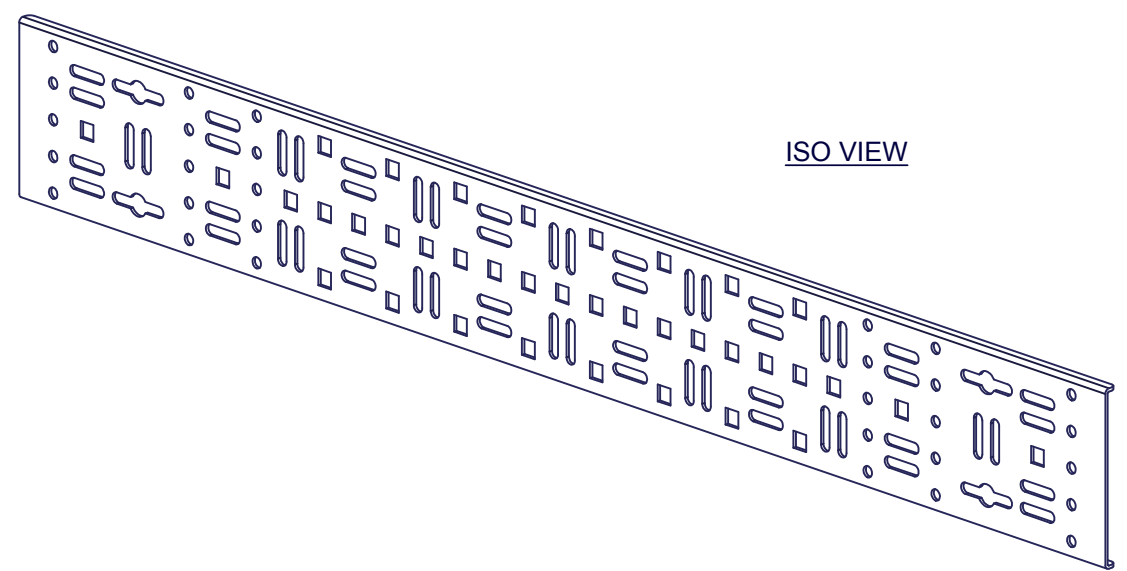

ISO VIEW

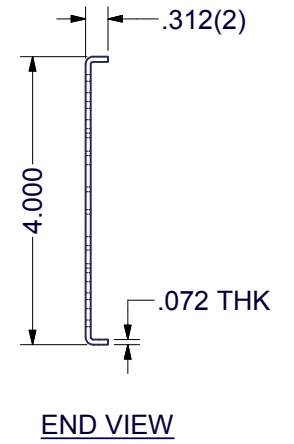
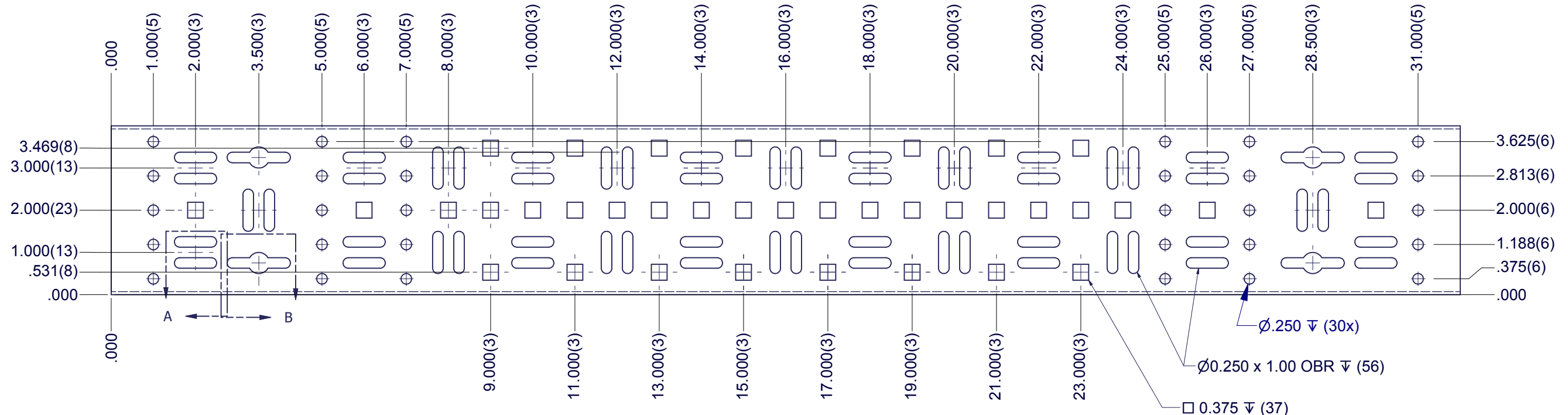
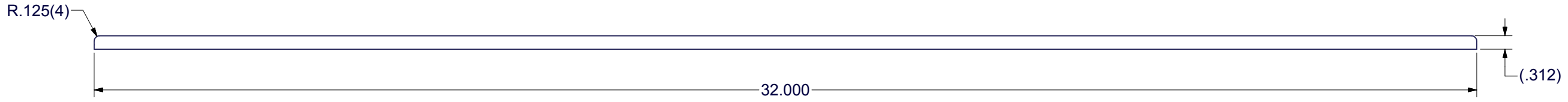

END VIEW

SPECIAL NOTES:

- 1) DIMENSIONS APPLY BEFORE APPLICATION OF FINISH: ADD .005" TO EACH SURFACE FOR INSPECTION.
- 2) TYPICAL BEND RADII = R0.030 x 90° INSIDE UNLESS NOTED OTHERWISE.
- 3) PREPARE ALL THREADS PRIOR TO WELD OR POWDERCOAT PER TD-09-109.
- 4) FINISH PER TD-09-103 (POWDER COAT), CLASS B, TEXTURE LEVEL 3, ALL SURFACES UNLESS NOTED OTHERWISE.
- 5) KIT HARDWARE WITH LACING BAR

EST. WEIGHT :
2.45 lbmass



INTERPRET DRAWING PER ASME Y14.5M-1994
DIMENSIONAL LIMITS APPLY AFTER APPLICATION OF FINISH
DRAWING NOT TO SCALE
TOLERANCE UNLESS OTHERWISE NOTED:
ANGULAR +/- .1°
.XXXX +/- .010
.XXX +/- .015
.XX +/- .030
.X FOR REF. ONLY
UNLESS OTHERWISE SPECIFIED ALL DIMENSIONS ARE IN INCHES

NOTICE:
Use of this document is subject to a confidentiality and nondisclosure agreement with Great Lakes Case & Cabinet Co., Inc. (GLCC) and may not be reproduced, disclosed or utilized in whole or in part without prior written authorization from GLCC.

PART NUMBER: VCB48x100
QTY PER UNIT: 1
MATERIAL TYPE: CRS
MATERIAL GAUGE:
FINISH: SEE NOTES
DRAWN FED CHECKED & APP. WSS
DATE 10/3/2014 DATE 10/1/2014

TITLE VERTICAL CABLE BAR FOR 48"H 'E/' 'ES' ENCLOSURE
GREAT LAKES CASE & CABINET CO., INC. P.O. BOX 551 EDINBORO, PA 16412 PHONE (814) 734-7303 FAX (814) 734-3907 E-MAIL glcc@greatcabinets.com
DWG NO: 1022482
REV 0
SHEET: 1 OF 1