

CONFIG PART #	
910ENT4048SSS	910EN4048SSS
EN FRAME 91"H x 40"W x 48"D w/ (2) PR OF 48 RMU, #10-32UNF TAPPED RAILS, CABLE MANGAGMENT FINGERS ON ALL RAILS, SOLID TOP PANEL, SPLIT MESH FRONT & REAR DOORS & (2) SOLID SIDE PANELS	EN FRAME 91"H x 40"W x 48"D w/ (2) PR OF 48 RMU, 3/8" SQUARE HOLES FOR M6 CAGE NUTS, CABLE MANAGEMENT FINGERS ON ALL RAILS, SOLID TOP PANEL, SPLIT MESH FRONT & REAR DOORS & (2) SOLID SIDE PANELS

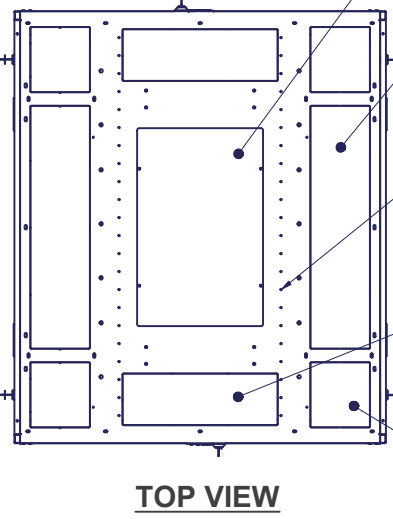

- TOP PANEL OPENING (273 sq in) SOLID, VENTED, OR w/ EXHAUST FANS FLOWING UP TO 1100 cfm
- 6.63 x 27.00 CABLE PASS-THROUGH KNOCK-OUT (179.0 sq in), (2) PLACES
- INDEPENDANT MOUNTING LOCATIONS FOR LADDER RACK BRACKETS OR TOP MOUNTED CABLE TROUGHS
- 5.75 x 17.25 CABLE PASS-THROUGH KNOCK-OUT (99.2 sq in), (2) PLACES
- 6.63 x 7.25 CABLE PASS-THROUGH KNOCK-OUTS (48.1 sq in), (4) PLACES

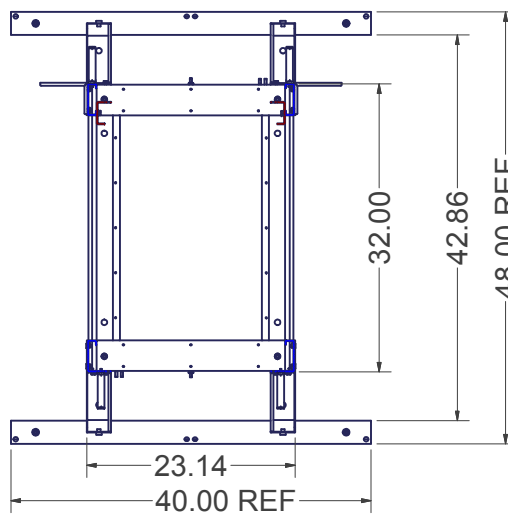
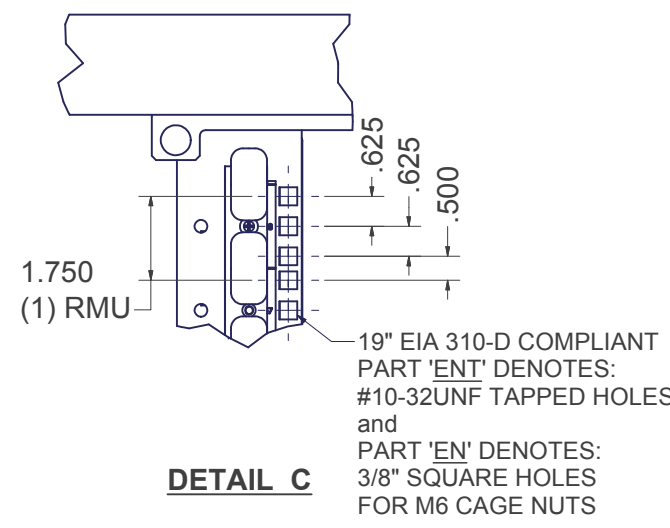
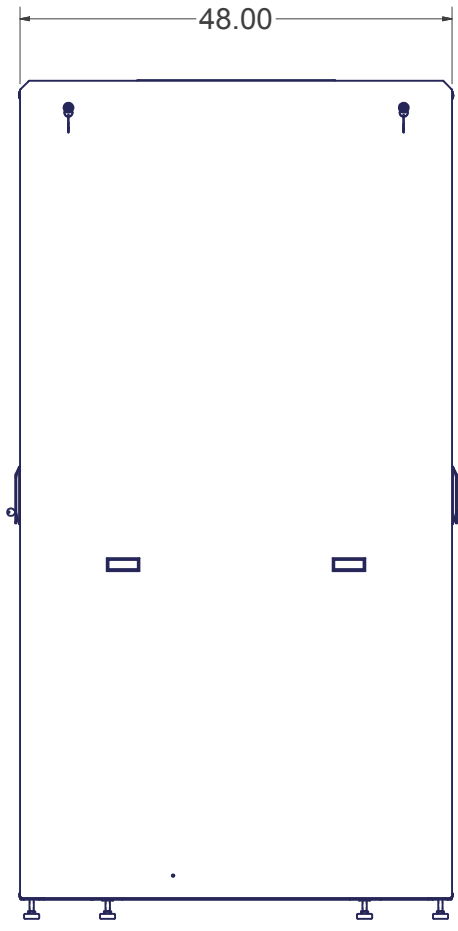
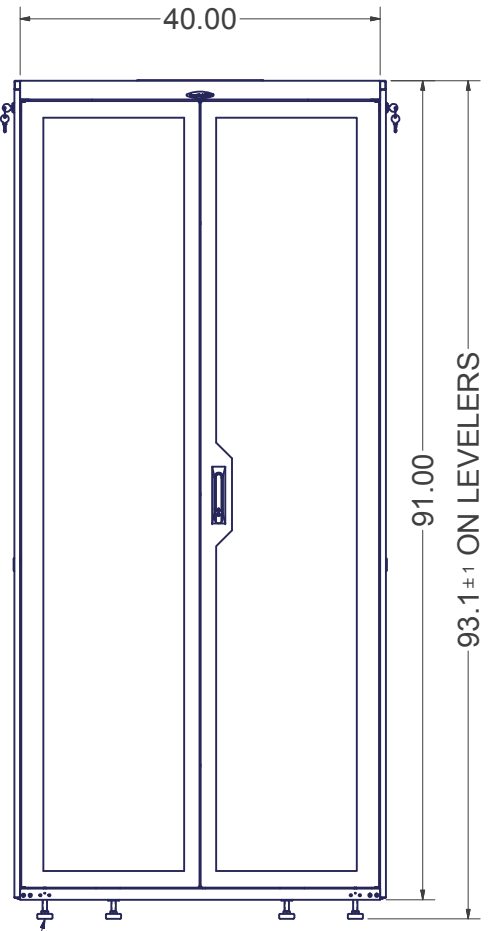
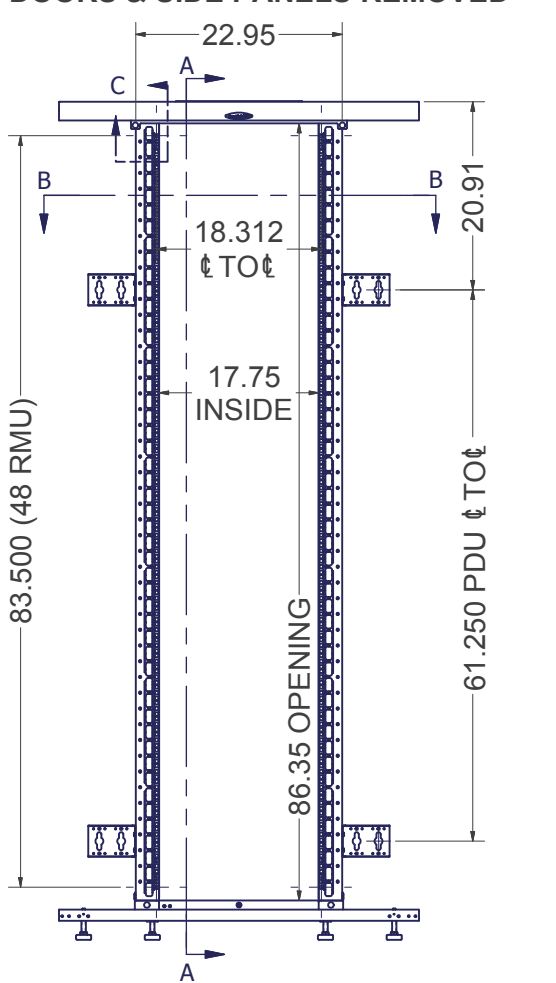
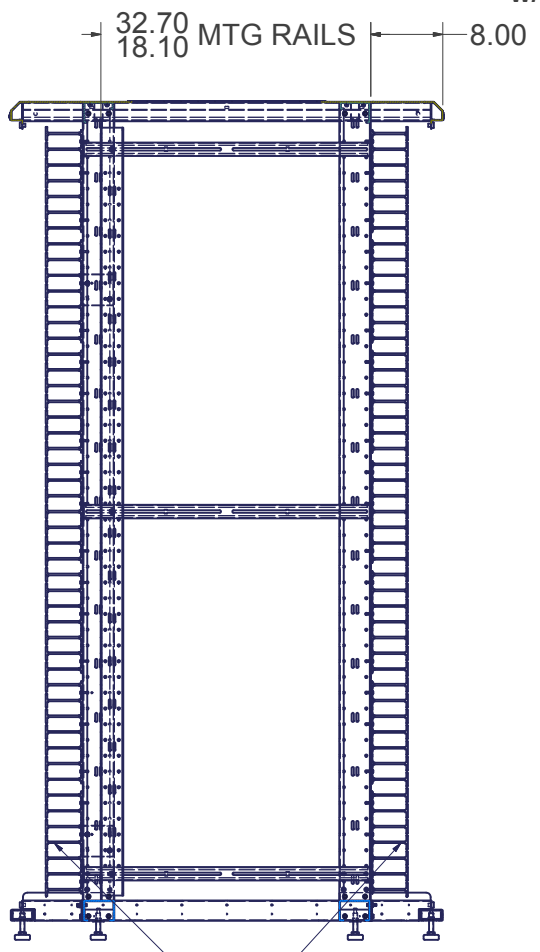
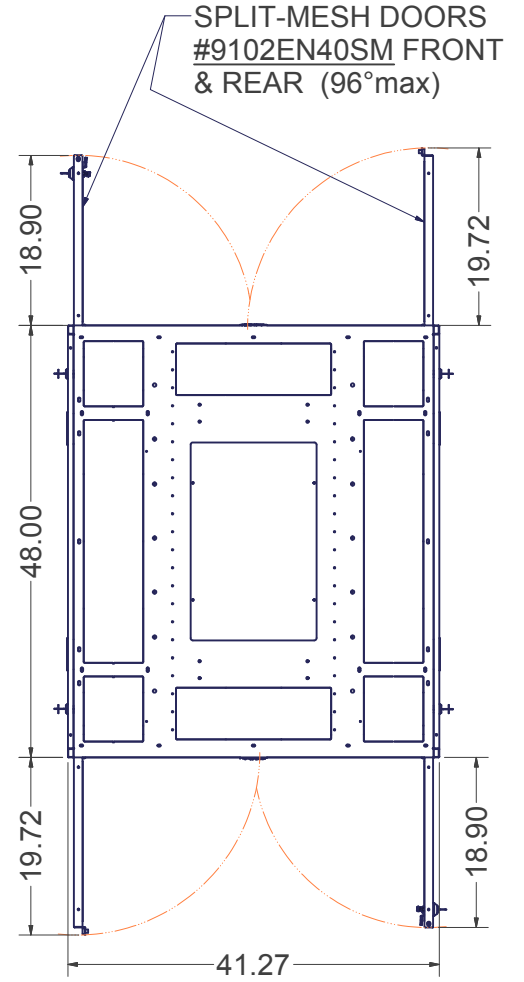
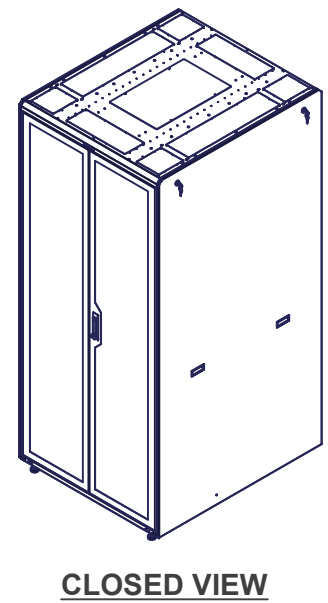

- SPECIFICATIONS:**
- DIMENSIONS:** 91"H (93" w/ LEVELERS) x 40"W x 48"D
 - RACK SPACES:** 48 RMU w/ NUMBERED RMU INDICATORS, 19" EIA 310-E COMPLIANT
 - WEIGHT CAPACITY:** 2000 lbs BOLTED TO FLOOR ON LEVELERS,
 - COLOR:** DURABLE TEXTURED BLACK POWDER COATING
 - CERTIFICATIONS:** UL 60950-1 STANDARD FOR IT & COMMUNICATIONS EQUIPMENT ENCLOSURES
 - CONSTRUCTION:** FULL WELDED STEEL FRAME w/ RECESSED #12 GA CORNER POSTS, 1 PR FIXED #12 GA RAILS, 1 PR OF ADJUSTABLE DEPTH #12 GA RAILS, DOORS OF #16 GA STEEL & SIDE PANELS OF LIGHTWEIGHT .060" ALUMINUM
 - HARDWARE:** PACKAGED (QTY 50), M6 OR #10-32 SCREWS & CAGE NUTS PER CUSTOMER REQUIREMENTS

EST. WEIGHT : 392.13 lbmass	INTERPRET DRAWING PER ASME Y14.5M-1994	NOTICE: Use of this document is subject to a confidentiality and nondisclosure agreement with Great Lakes Case & Cabinet Co., Inc. (GLCC) and may not be reproduced, disclosed or utilized in whole or in part without prior written authorization from GLCC.	PART NUMBER: SEE CHART	TITLE 'EN' SERIES ENCLOSURE, 91"H x 40"W x 48"D, w/ SOLID TOP, FRONT & REAR SPLIT MESH DOORS & SOLID SIDE PANELS
	DIMENSIONAL LIMITS APPLY AFTER APPLICATION OF FINISH		QTY PER UNIT: 1	GREAT LAKES CASE & CABINET CO., INC. P.O. BOX 551 EDINBORO, PA 16412 PHONE (814) 734-7303 FAX (814) 734-3907 E-MAIL glcc@greatcabinets.com
THIRD ANGLE PROJECTION	DRAWING NOT TO SCALE	UNLESS OTHERWISE SPECIFIED ALL DIMENSIONS ARE IN INCHES	MATERIAL TYPE:	DWG NO.:
	TOLERANCE UNLESS OTHERWISE NOTED: ANGULAR +/- .1' .XXXX +/- .010 .XXX +/- .015 .XX +/- .030 .X FOR REF. ONLY		FINISH:	REV:
			DRAWN DATE: 1/23/2014	DATE: 1/23/2014
			CHECKED & APP. DATE: 2/8/2011	DATE: 2/8/2011
			WSS	WSS
			SEE CHART	SEE CHART
				SHEET: 1 OF 1