

REVISION HISTORY			
REV	DESCRIPTION	DATE	APPROVED
0	ECO-03097	1/11/2011	MZ
1	ECO-03902	6/3/2012	PCS

Bill of Material						
ITEM	PART NUMBER	STOCK NUMBER	QTY	DESCRIPTION	FILE NAME	REVISION
1			2	BASE ANGLE FOR GLRR-1984 RELAY RACK	I002709.ipt	5
2	500-13X1HHB		12	BOLT, 1/2"-13 x 1" HEX HD	500-13X1HHB.ipt	-
3	500SPLWSHR		12	WASHER, 1/2" SPLIT LOCK, STEEL	500SPLWSHR.ipt	-
4	GL-NAMEPLATE		1	GLCC NAME PLATE, AL., 3" x .75" w/ "3MLSE9495" ADHESIVE, LaFrance Corp.	GL-NAMEPLATE.ipt	-
5			2	VERTICAL CHANNEL FOR 66"H TWO POST RACK	I013257.ipt	0
6			2	TOP ANGLE FOR GLRR-1984 RELAY RACK	I002710.ipt	7
7			1	PACKAGING MATERIAL FOR 108"H TWO POST RACK	-	-
8			1	ASSEMBLY INSTRUCTION: FORM #05-10	-	-
9	12/24X1/223SC		50	#12-24 x 1/2"L PAN HD PHIL TYPE 23 ZN PL SCREW	-	-

<b>GLCC PART NO:</b>	<b>FINISH</b>
<b>GLRR1966BAX200</b>	<b>BLACK ANODIZED</b>
<b>GLRR1966AEX200</b>	<b>ACID ETCHED &amp; ANODIZED</b>

**SPECIAL NOTES:**

- ATTACH CAUTION LABEL ON ONE OF THE BASE ANGLES - CENTERED. THE LABEL SHOULD STATE: "CAUTION - RACK MUST BE FIRMLY ANCHORED TO FLOOR. CONCRETE FLOOR SURFACE RECOMMENDED."
- TWO POST RACK TO BE SHIPPED UNASSEMBLED.
- SHIPPING BOX TO CONTAIN ONE PACK OF (50) #12-24 x 1/2"L MOUNTING SCREWS AND AN ASSEMBLY INSTRUCTION.

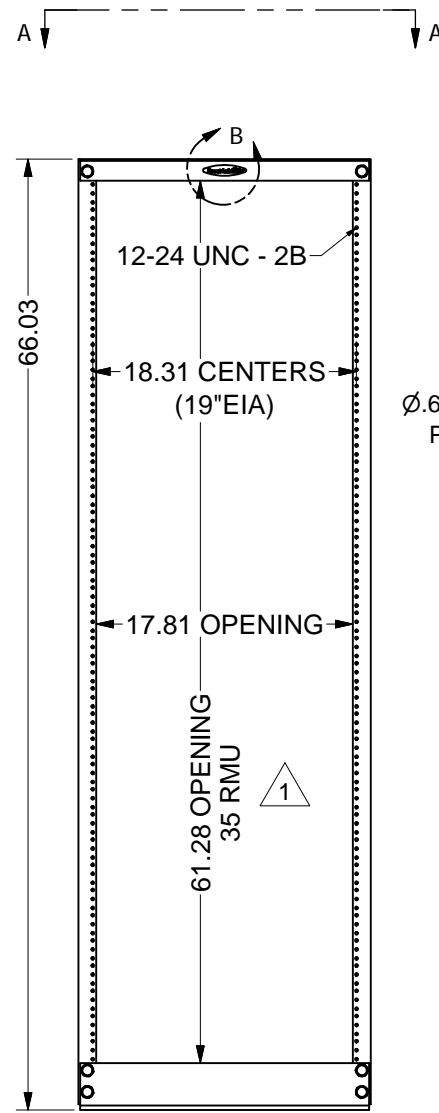
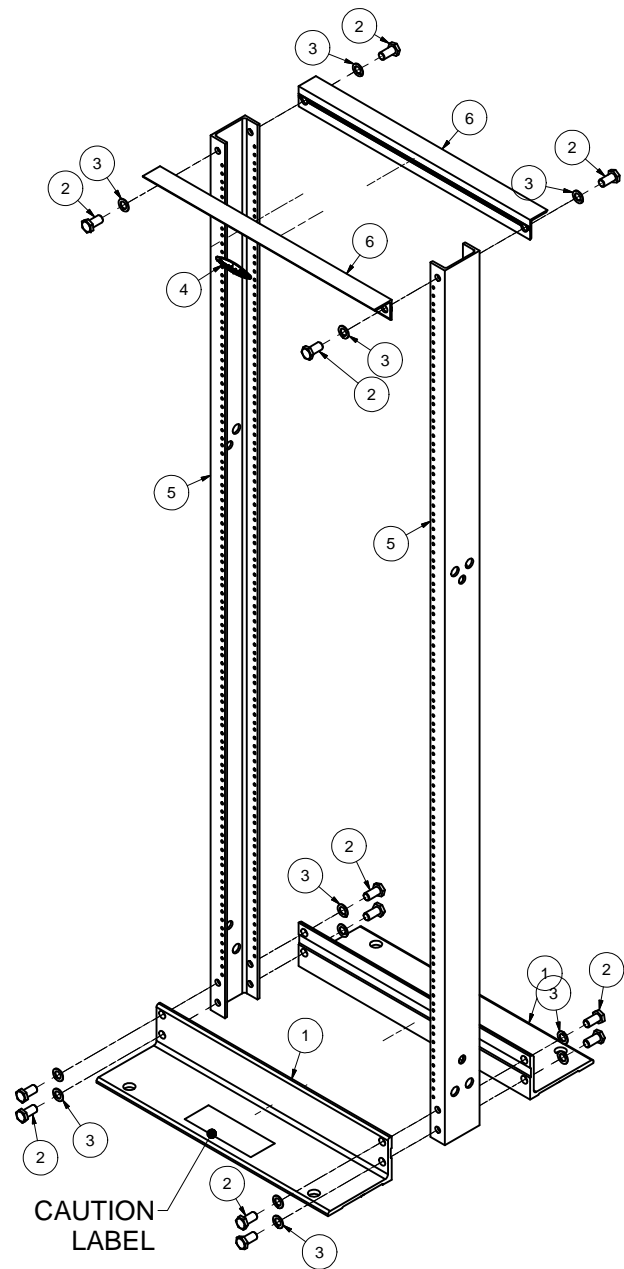

FRONT VIEW

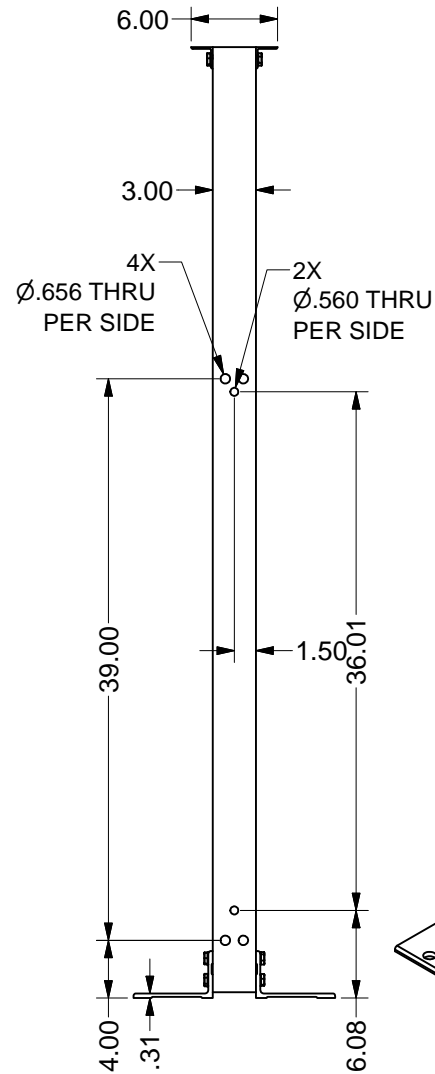

RIGHT SIDE VIEW

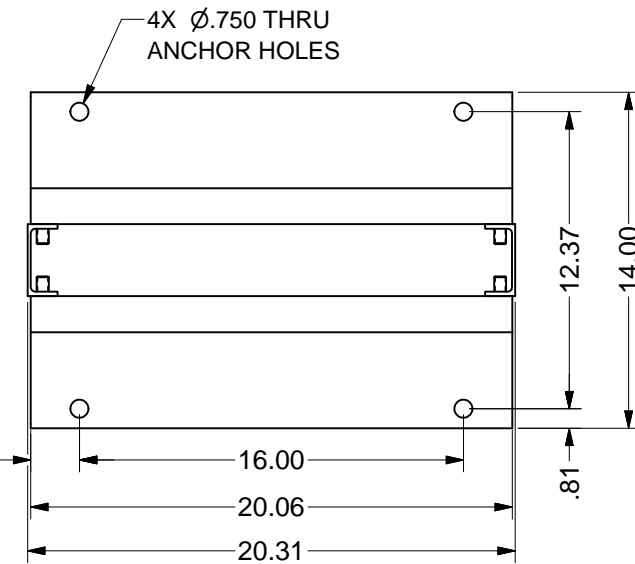
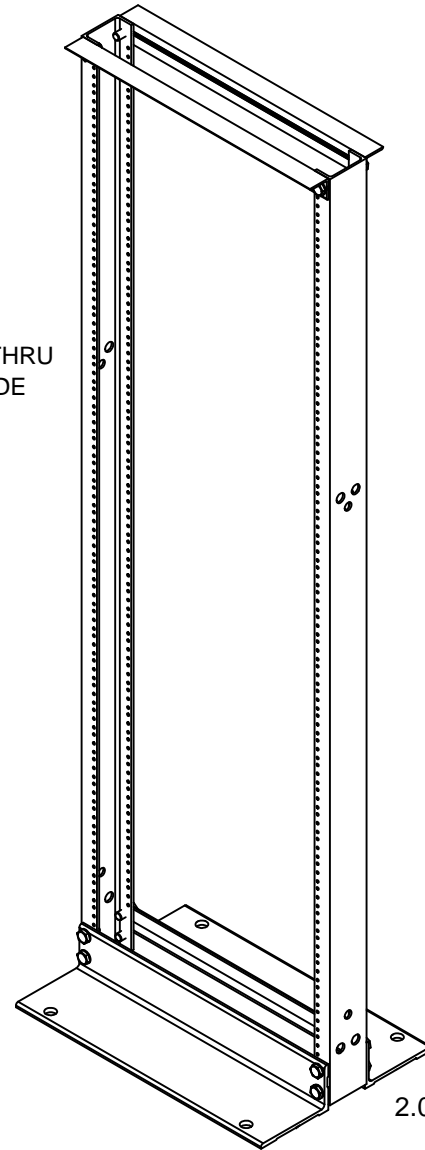

VIEW A-A  
SCALE .25



**DETAIL B**  
INSTALL ITEM #4 AS SHOWN.  
ONE LABEL CENTERED  
ON ONE OF TOP ANGLES.

INTERPRET DRAWING PER ASME Y14.5M-1994
DIMENSIONAL LIMITS APPLY AFTER APPLICATION OF FINISH
DRAWING NOT TO SCALE
TOLERANCE UNLESS OTHERWISE NOTED:
ANGULAR +/- 1°
.XXXX +/- .010
.XXX +/- .015
.XX +/- .030
.X FOR REF. ONLY
UNLESS OTHERWISE SPECIFIED ALL DIMENSIONS ARE IN INCHES

**NOTICE:**  
Use of this document is subject to a confidentiality and nondisclosure agreement with Great Lakes Case & Cabinet Co., Inc. (GLCC) and may not be reproduced, disclosed or utilized in whole or in part without prior written authorization from GLCC.

PART NUMBER:	
QTY PER UNIT:	1
MATERIAL TYPE:	
MATERIAL GAUGE:	
FINISH:	SEE NOTES
DRAWN:	DATE
MZ	1/11/2011
CHECKED & APP.:	DATE
WSS	1/11/2011

TITLE:	2 POST RACK, 66"H x 20.31"W x 14"D, WT. CAP. 1500 LBS, 35 RMU		
GREAT LAKES CASE & CABINET CO., INC.			
P.O. BOX 551 EDINBORO, PA 16412			
PHONE (814) 734-7303 FAX (814) 734-3907			
E-MAIL glcc@greatcabinets.com			
DWG NO:	REV	SHEET: 1 OF 1	
I013256	1		



THIRD ANGLE PROJECTION