

REVISION HISTORY			
REV	DESCRIPTION	DATE	APPROVED
4	ECO-02026	9/14/2007	WSS
5	ECO-02076	11/05/2007	WSS

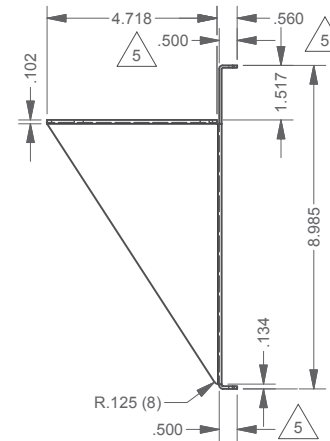
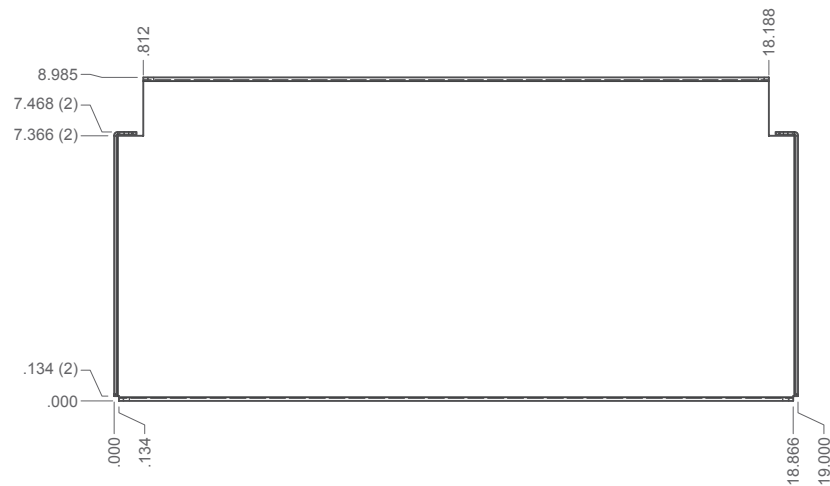
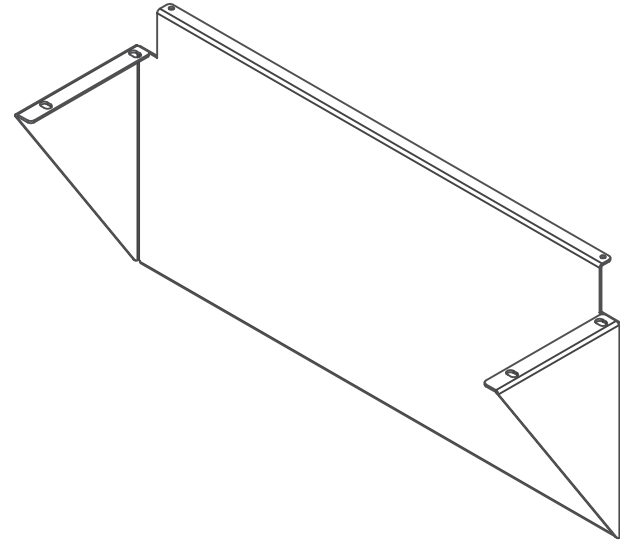
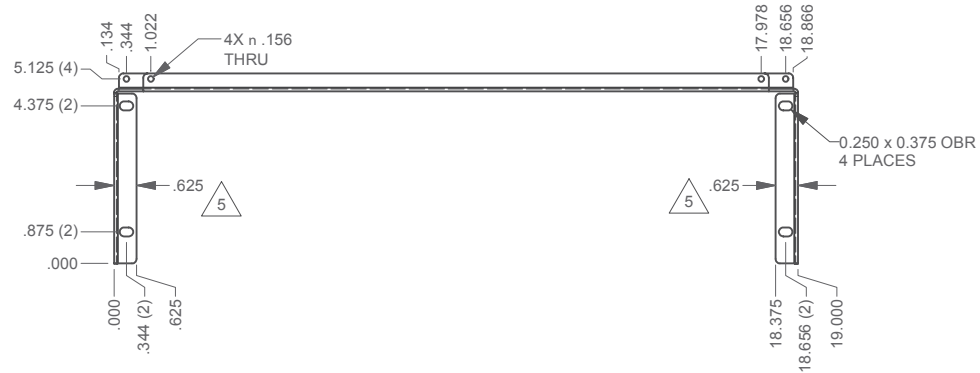

**SPECIAL NOTES:**

1. FINISH PER TD-09-103 (POWDER COAT), CLASS B, TEXTURE LEVEL 3,- ALL SURFACES UNLESS OTHERWISE NOTED.
2. DIMENSIONS APPLY AFTER APPLICATION OF FINISH.
3. TYPICAL BEND RADIUS = 0.060
4. ALL BENDS ARE 90° UNLESS OTHERWISE SPECIFIED

INTERPRET DRAWING PER ASME Y14.5M-1994
DIMENSIONAL LIMITS APPLY AFTER APPLICATION OF FINISH
DRAWING NOT TO SCALE
TOLERANCE UNLESS OTHERWISE NOTED:
ANGULAR +/- 1-
.XXXX +/- .010
.XXX +/- .015
.XX +/- .030
.X FOR REF. ONLY
UNLESS OTHERWISE SPECIFIED ALL DIMENSIONS ARE IN INCHES

**NOTICE:**

Use of this document is subject to a confidentiality and nondisclosure agreement with Great Lakes Case & Cabinet Co., Inc. (GLCC) and may not be reproduced, disclosed or utilized in whole or in part without prior written authorization from GLCC.

PART NUMBER:	1984ST09
QTY PER UNIT:	1
MATERIAL TYPE:	CRS
MATERIAL GAUGE:	14 GA
FINISH:	SEE NOTES
DRAWN	DATE
DW	9/14/2007
CHECKED & APP.	DATE
WSS	9/14/07

TITLE	19" EIA SHELF, 9" DEEP	
GREAT LAKES CASE & CABINET CO., INC.		
P.O. BOX 551 EDINBORO, PA 16412		
PHONE (814) 734-7303 FAX (814) 734-3907		
E-MAIL glcc@greatcabinets.com		
DWG NO:	REV	SHEET: 1 OF 1
1005943	5	

