

REVISION HISTORY			
REV	DESCRIPTION	DATE	APPROVED
0	ECO-01861	2/12/2007	JL
1	ECO-02099	12/3/07	WSS

Bill of Material					
ITEM	PART NUMBER	QTY	DESCRIPTION	FILE NAME	REV
1		1	SIDE PANEL WELDMENT, VENTED LIFT-OFF FOR 72H x 36D E CABINETS	I005021.iam	1
2	10117-32728	1	Austin Hardware 10117-32728 Black Die cast Lock	10117-32728.iam	-
3	2000614	1	CAM FOR SIDE PANELS	2000614.ipt	-
4	A34062512	2	SOUTHCO SLIDE LATCH, FLUSH	A34062512.ipt	-

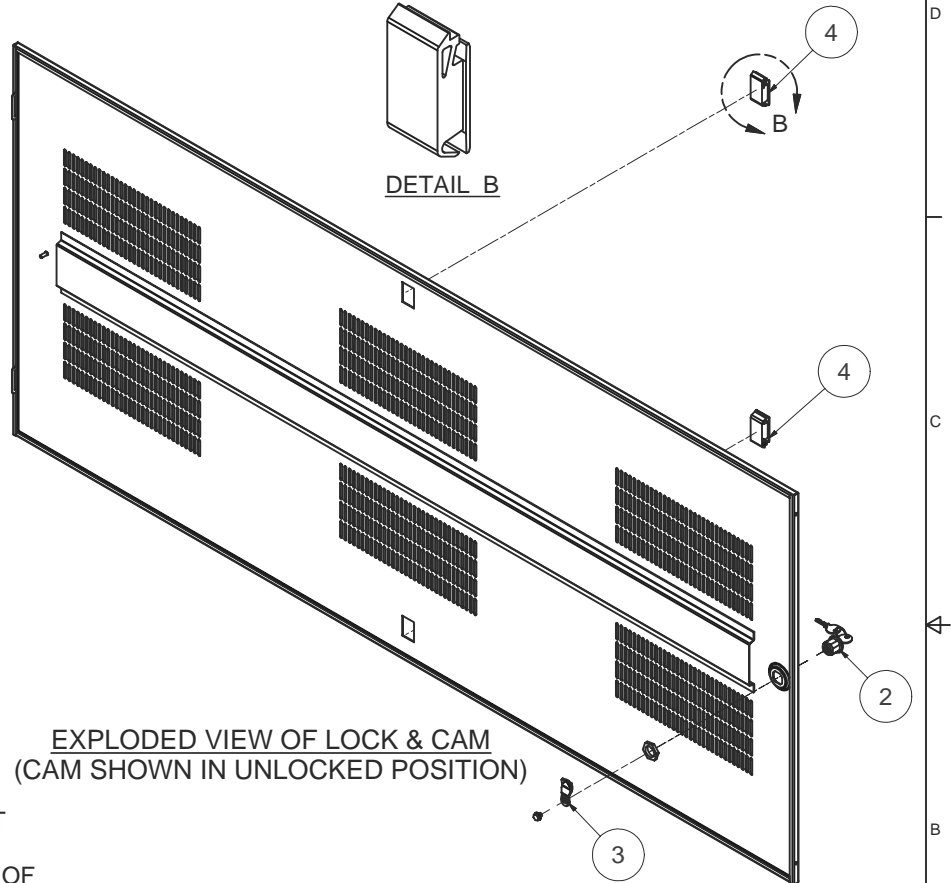
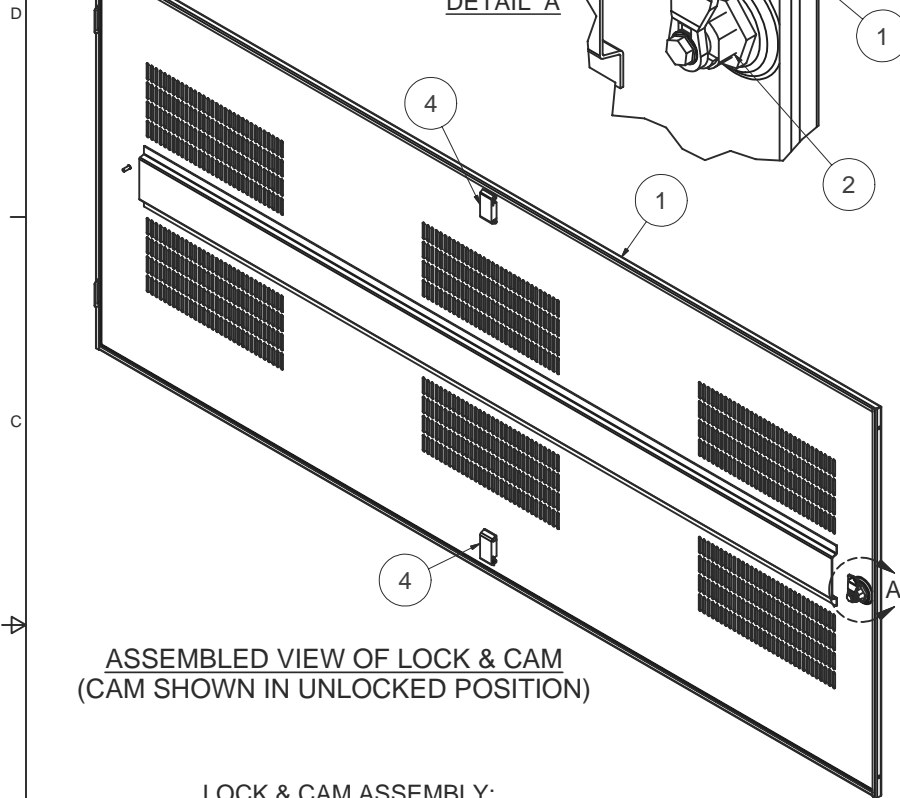

ASSEMBLED VIEW OF LOCK & CAM
(CAM SHOWN IN UNLOCKED POSITION)

EXPLODED VIEW OF LOCK & CAM
(CAM SHOWN IN UNLOCKED POSITION)

LOCK & CAM ASSEMBLY:

- 1) DO NOT REMOVE KEY FROM LOCK CYLINDER WHEN CYLINDER IS NOT IN THE LOCK HOUSING, LOCK MECHANISM WILL BE DESTROYED.
- 2) POSITION LOCK HOUSING AS SHOWN IN VIEW 3 - NOTE ORIENTATION OF NOTCH ON ITS INSIDE SURFACE AND THE ORIENTATION OF THE KEY IN CYLINDER.
- 3) SECURE LOCK HOUSING WITH NUT.
- 4) POSITION CAM AS SHOWN AND SECURE WITH SCREW.
- 5) TURN KEY TO VERIFY SMOOTH OPERATION OF LOCK.

LATCH ASSEMBLY:

- 1) SLIP FRONT OF LATCH (OPPOSITE END WITH SPRING) THROUGH HOLE IN SIDE PANEL.
- 2) SNAP BACK END OF LATCH INTO POSITION.
- 3) LATCH MUST TRAVEL FREELY ONCE INSTALLED - PULL LATCH BACK AGAINST ITS SPRING AND RELEASE. LATCH MUST TRAVEL BACK 1/4" UNDER ITS OWN SPRING TENSION.

NOTCH IN HOUSING
ORIENT THIS SURFACE TOWARD TOP OF PANEL

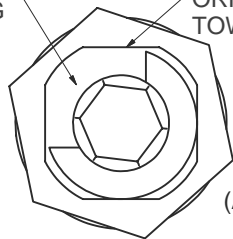

VIEW3 - LOCK DETAIL
(AS VIEWED FROM INSIDE)



INTERPRET DRAWING PER ASME Y14.5M-1994
DIMENSIONAL LIMITS APPLY AFTER APPLICATION OF FINISH
DRAWING NOT TO SCALE
TOLERANCE UNLESS OTHERWISE NOTED:
ANGULAR +/- 1'
.XXXX +/- .010
.XXX +/- .015
.XX +/- .030
.X FOR REF. ONLY
UNLESS OTHERWISE SPECIFIED ALL DIMENSIONS ARE IN INCHES

NOTICE:
Use of this document is subject to a confidentiality and nondisclosure agreement with Great Lakes Case & Cabinet Co., Inc. (GLCC) and may not be reproduced, disclosed or utilized in whole or in part without prior written authorization from GLCC.

PART NUMBER:	7211361ELLX100
QTY PER UNIT:	1
MATERIAL TYPE:	-
MATERIAL GAUGE:	-
FINISH:	-
DRAWN	DATE
JAL	4/29/2003
CHECKED & APP.	DATE
WSS	2-12-07

TITLE		SIDE PANEL VENTED LIFT-OFF FOR 72H x 36D E CABINET, ASSEMBLY	
GREAT LAKES CASE & CABINET CO., INC.			
P.O. BOX 551 EDINBORO, PA 16412			
PHONE (814) 734-7303 FAX (814) 734-3907			
E-MAIL glcc@greatcabinets.com			
DWG NO:	REV	SHEET: 1 OF 1	
I005020	1		

REVISION HISTORY			
REV	DESCRIPTION	DATE	APPROVED
0	ECO-01861	2/12/2007	JL
1	ECO-02099	12/3/07	WSS

Bill of Material					
ITEM	PART NUMBER	QTY	DESCRIPTION	FILE NAME	REV
1		1	STIFFENER FOR 72" H E CABINET LIFT-OFF SIDE PANELS	1000224.ipt	4
2	101208260	1	#10-32 x 1/2"L WELD STUD (NELSON)	101208260.ipt	-
3		1	SIDE PANEL, VENTED, LIFTOFF, FOR 72H x 36D E CABINET	1005022.ipt	0

SPECIAL NOTES:

- 1) FINISH PER TD-09-103 (POWDER COAT), CLASS B, TEXTURE LEVEL 3, - ALL SURFACES UNLESS OTHERWISE NOTED.
- 2) DIMENSIONS APPLY BEFORE APPLICATION OF FINISH: ADD .005" TO EACH SURFACE FOR INSPECTION.
- 3) INSTALL THE ITEM #2 WELD STUD ON THE CENTER PUNCH MARK.

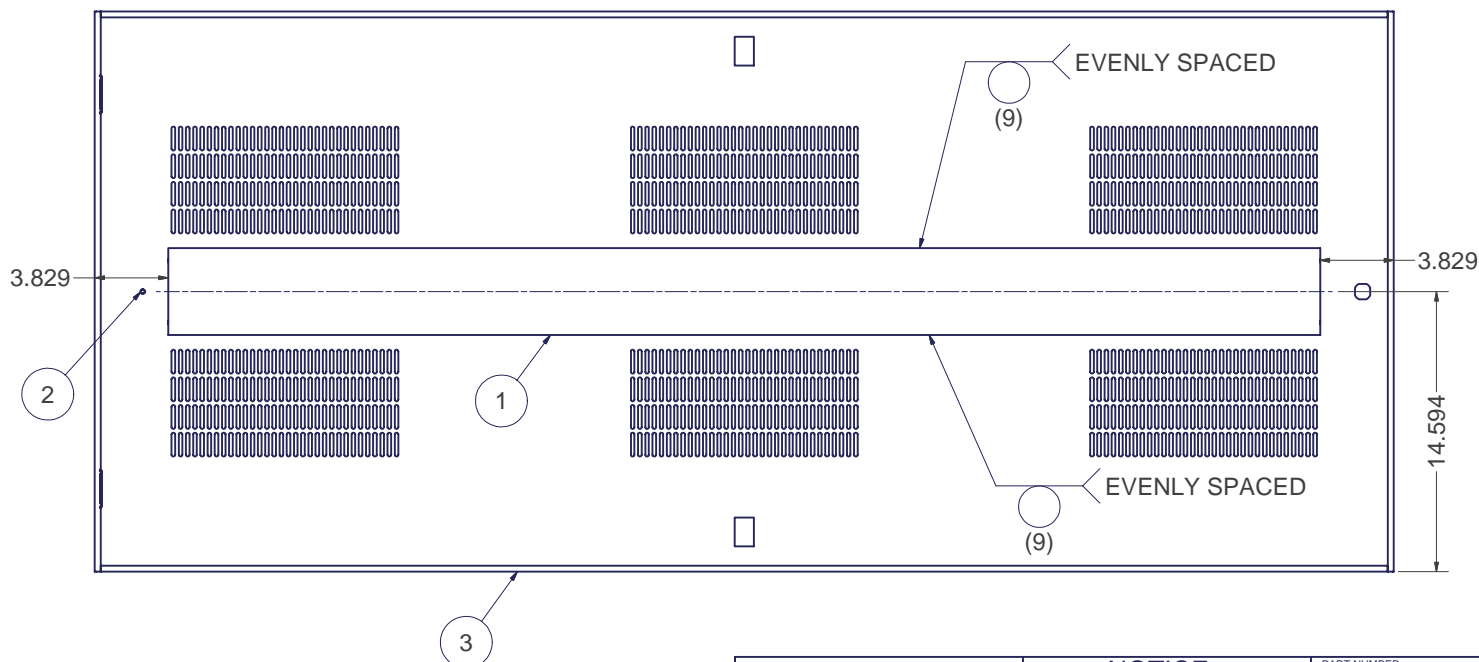
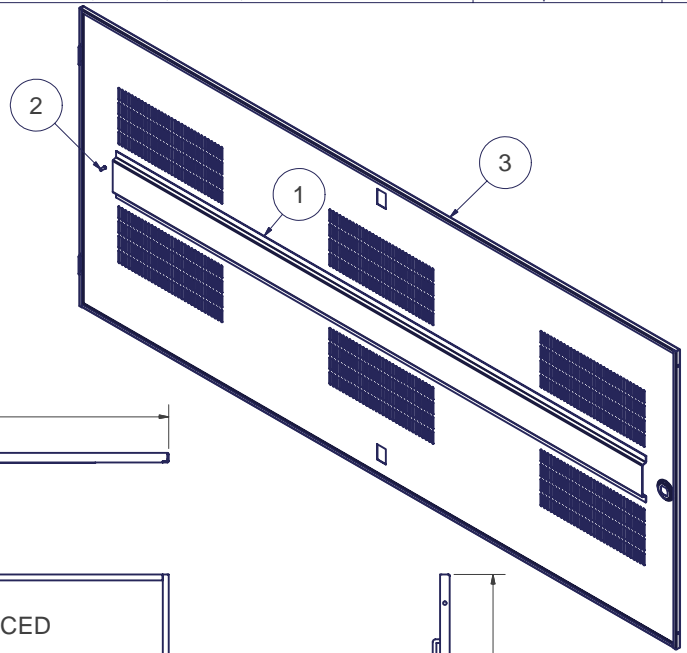

INTERPRET DRAWING PER ASME Y14.5M-1994
 DIMENSIONAL LIMITS APPLY AFTER APPLICATION OF FINISH
 DRAWING NOT TO SCALE
 TOLERANCE UNLESS OTHERWISE NOTED:
 ANGULAR +/- 1'
 .XXXX +/- .010
 .XXX +/- .015
 .XX +/- .030
 .X FOR REF. ONLY
 UNLESS OTHERWISE SPECIFIED ALL DIMENSIONS ARE IN INCHES

NOTICE:
 Use of this document is subject to a confidentiality and nondisclosure agreement with Great Lakes Case & Cabinet Co., Inc. (GLCC) and may not be reproduced, disclosed or utilized in whole or in part without prior written authorization from GLCC.

PART NUMBER:
 QTY PER UNIT: 1
 MATERIAL TYPE:
 MATERIAL GAUGE:
 FINISH: SEE NOTES
 DRAWN: JAL DATE: 4/29/2003
 CHECKED & APP. DATE: 2-12-07
 WSS

TITLE: **SIDE PANEL WELDMENT, VENTED LIFTOFF FOR 72H x 36D E CABINETS**
GREAT LAKES CASE & CABINET CO., INC.
 P.O. BOX 551 EDINBORO, PA 16412
 PHONE (814) 734-7303 FAX (814) 734-3907
 E-MAIL glcc@greatcabinets.com
 DWG NO: 1005021
 REV: 1
 SHEET: 1 OF 1

